

valvole ad azionamento elettropneumatico

solenoid actuated valves

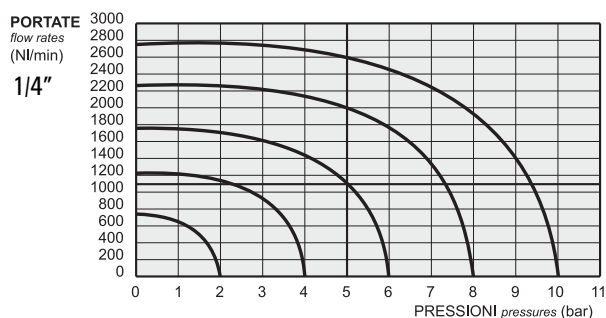

- Valvole a spola 3/2-5/2-5/3 con attacchi filettati G1/8"-G1/4"
3/2-5/2-5/3 spool valves with G1/8"-G1/4" threaded ports
- Montaggio in linea, su collettori multipli o su basi manifold
Installation in-line, on gang or modular manifolds
- Comandi elettrici con azionamento manuale bistabile
Solenoid pilots with detented manual override as standard
- A richiesta versione a basso assorbimento 1.5W
On request with low consumption 1.5W
- Esecuzioni speciali a richiesta
Special versions on request

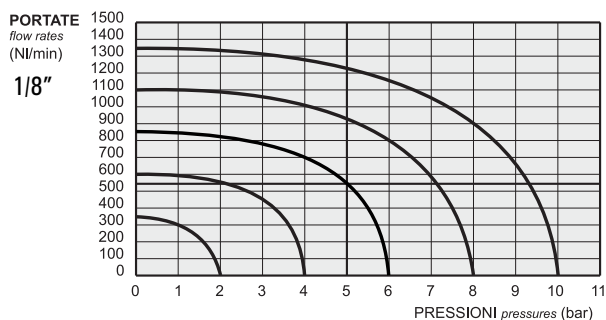
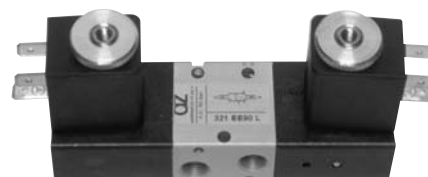

Materiali

Corpo: alluminio 11S

Comando e fondello: tecnopolimero (*)

Molle: INOX

Guarnizioni: NBR

Spola: alluminio nichelato

Parti interne: ottone OT58

Materials

Body: aluminium 11S

End caps: technopolymer (*)

Springs: stainless steel

Seals: NBR

Spool: nickel plated aluminium

Internal parts: brass OT58

(*) Su richiesta e dietro supplemento di prezzo, le valvole sono fornibili con corpo, comando e fondello interamente in alluminio. Alcune valvole, come di seguito specificato, sono disponibili solo nella versione in alluminio. Le valvole ATEX sono solo in alluminio.

Le parti in tecnopolimero recano impresso il logo

(*) On request and upon extra charge, the valves are available also with body and end caps entirely in aluminium. Some valves, as specified in the next pages, are available only in the aluminium version. ATEX valves are only in aluminium.

The parts in technopolymer are marked with the logo

Tempi di risposta - response times

	1/8"	1/4"
monostabile <i>mono-stable</i>	TRA (14): 15 ms TRR (12): 35 ms	TRA (14): 19 ms TRR (12): 45 ms
bistabile <i>bi-stable</i>	TRA (14): 20 ms TRR (12): 20 ms	TRA (14): 22 ms TRR (12): 22 ms

I prodotti di seguito indicati sono venduti senza bobine, da acquistarsi separatamente (vedi pag. 209).
The following listed products are sold without coils, which are bought separately (refer to page 209).

Diametro nominale <i>Nominal orifice</i>	1/8": 5 mm 1/4": 7.5 mm		
Temperatura di esercizio <i>Temperature range</i>	max +60°C		
Pressione di esercizio <i>Working pressure</i>	al. interna monost. [monost. internal air supply]	al. interna bist. [bi-stable internal air supply]	alim. separata [separate air supply]
	2.5 ... 10 bar 0.25 ... 1 MPa	1 ... 10 bar 0.1 ... 1 MPa	-0.9 ... 10 bar -0.09 ... 1 MPa
Pressione di azionamento (per alimentazione separata) <i>Actuating pressure (for separate air supply)</i>	monostabile [mono-stable]		bistabile [bi-stable]
	2.5 ... 10 bar 0.25 ... 1 MPa		1 ... 10 bar 0.1 ... 1 MPa
Fluido <i>Fluid</i>	Aria filtrata 50µ con o senza lubrificazione <i>50µ filtered, lubricated or non lubricated air</i>		

valvole ad azionamento elettropneumatico

solenoid actuated valves



321 ME

3/2 1/8" NC comando elettrico - ritorno a molla

3/2 1/8" NC solenoid pilot - spring return

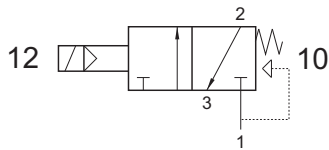

Non può essere utilizzata come valvola normalmente aperta.
It cannot be used as normally open valve.

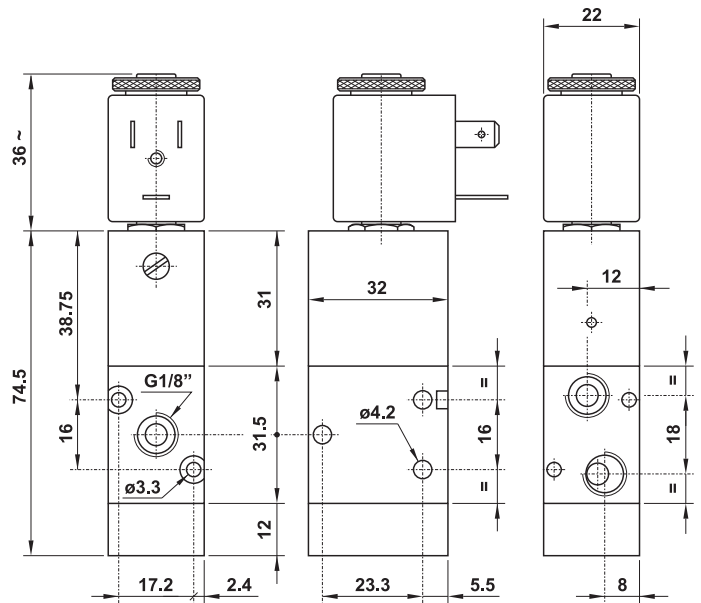

321 MEA

3/2 1/8" NA comando elettrico - ritorno a molla

3/2 1/8" NO solenoid pilot - spring return

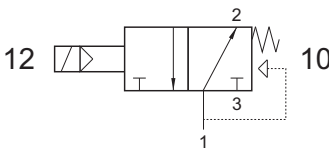

Non può essere utilizzata come valvola normalmente chiusa.
It cannot be used as normally closed valve.

SOLO VERSIONE IN ALLUMINIO
ONLY ALUMINIUM VERSION

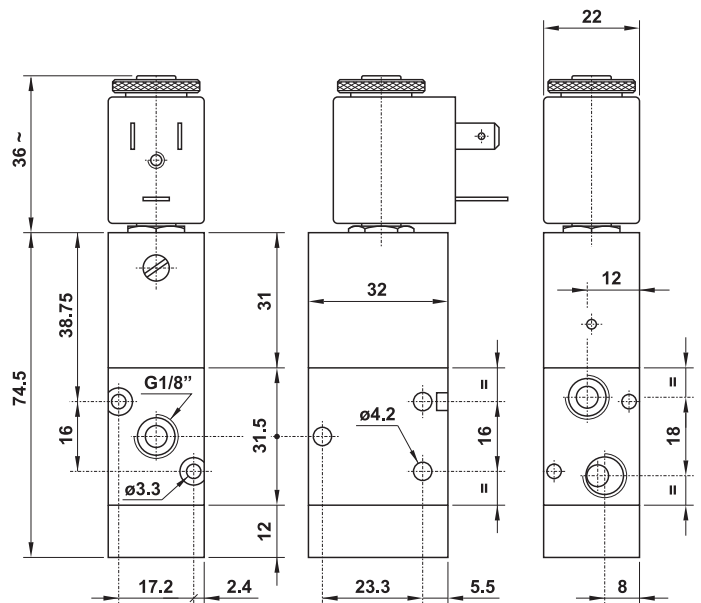

321 CE

3/2 1/8" comando elettrico - ritorno a comando pneumatico

3/2 1/8" solenoid pilot - separate pneumatically piloted return

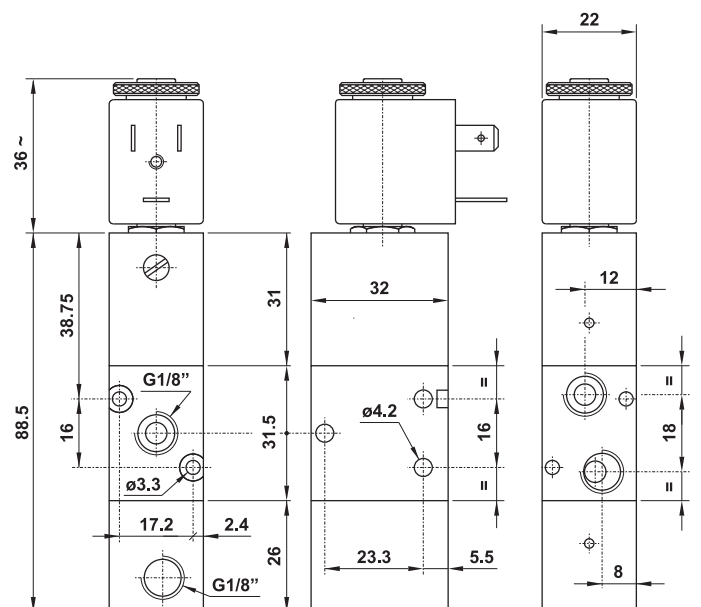
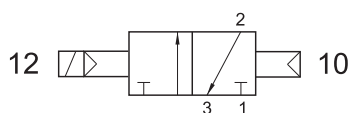

valvole ad azionamento elettropneumatico

solenoid actuated valves



521 ME

5/2 1/8" comando elettrico - ritorno a molla

5/2 1/8" solenoid pilot - spring return

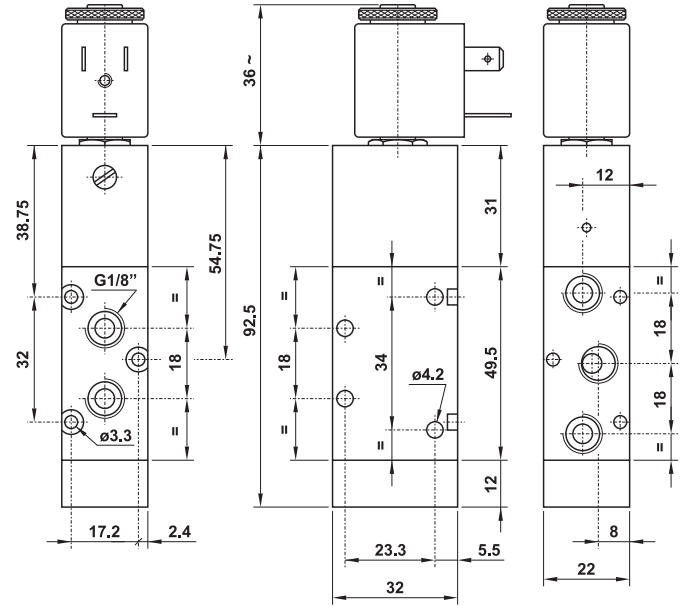
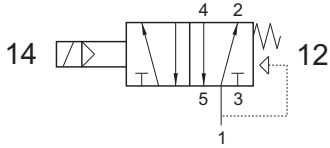

521 CE

5/2 1/8" comando elettrico - ritorno a comando pneumatico

5/2 1/8" solenoid pilot - separate pneumatically piloted return

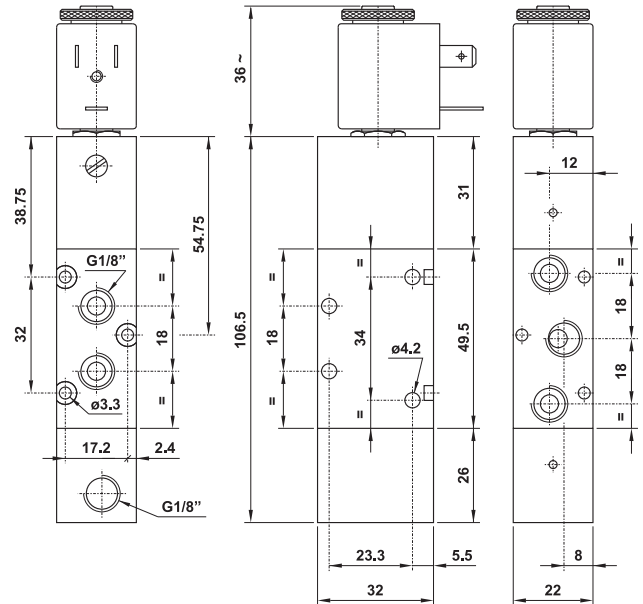
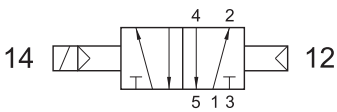

321 ME AS

3/2 1/8" comando elettrico alimentazione separata - ritorno a molla

3/2 1/8" solenoid pilot with separate air supply - spring return

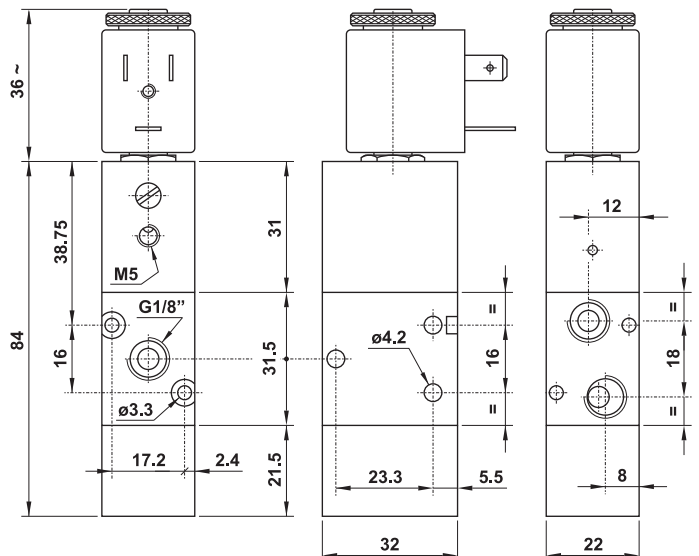
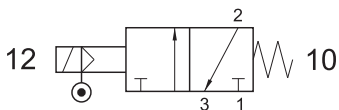

valvole ad azionamento elettropneumatico

solenoid actuated valves



521 ME AS

5/2 1/8" comando elettrico alimentazione separata - ritorno a molla

5/2 1/8" solenoid pilot with separate air supply - spring return

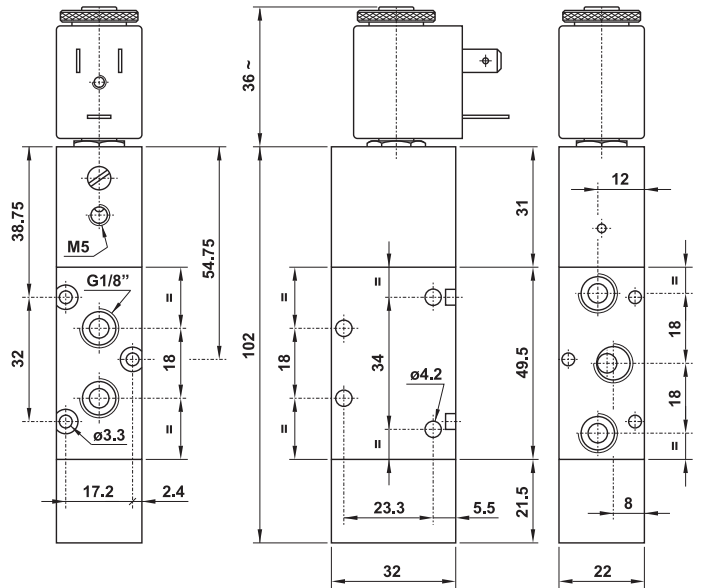
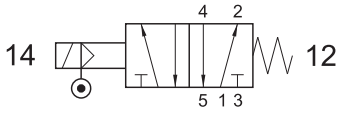

321 EE

3/2 1/8" doppio comando elettrico

3/2 1/8" double solenoid pilot

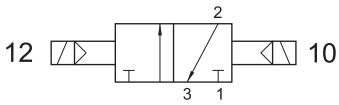

SOLO VERSIONE IN ALLUMINIO
ONLY ALUMINIUM VERSION

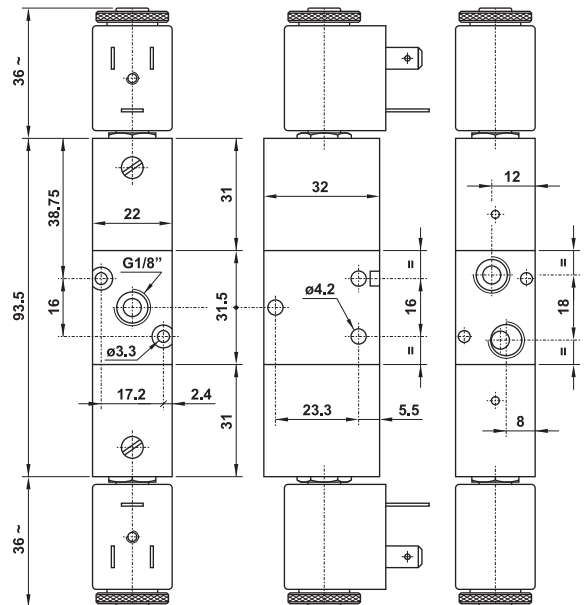

321 EED

3/2 1/8" doppio comando elettrico - con differenziale

3/2 1/8" double solenoid pilot - with differential

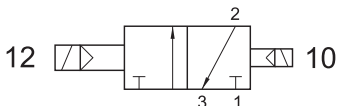

SOLO VERSIONE IN ALLUMINIO
ONLY ALUMINIUM VERSION

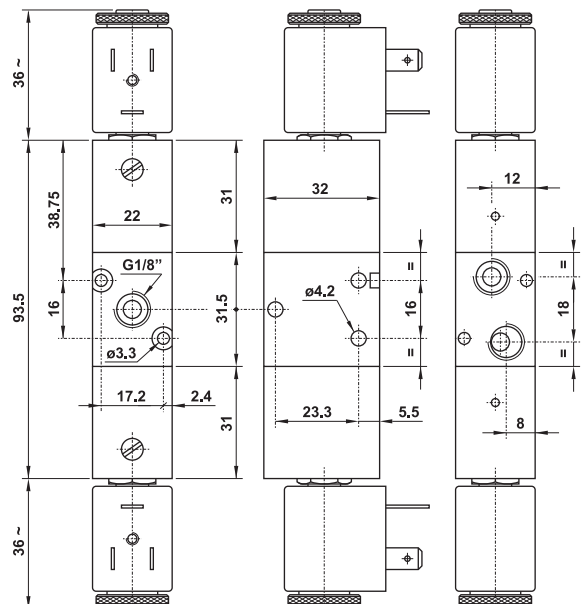

valvole ad azionamento elettropneumatico

solenoid actuated valves



321 EFP

3/2 1/8" NC comando elettrico - ritorno a molla pneumatica

3/2 1/8" NC solenoid pilot - pneumatic spring return

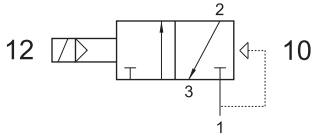

Non può essere utilizzata come valvola normalmente aperta.
It cannot be used as normally open valve.

SOLO VERSIONE IN ALLUMINIO
ONLY ALUMINIUM VERSION

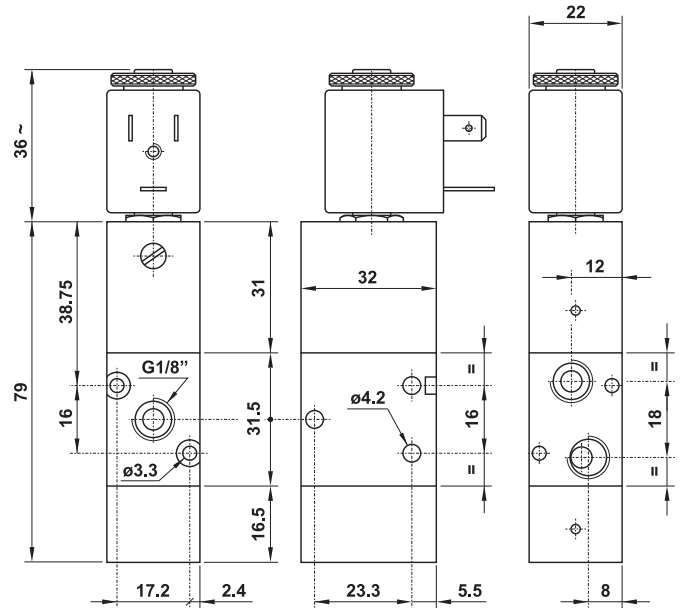

521 EE

5/2 1/8" doppio comando elettrico

5/2 1/8" double solenoid pilot

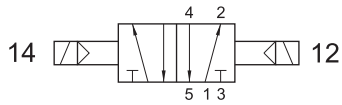

SOLO VERSIONE IN ALLUMINIO
ONLY ALUMINIUM VERSION

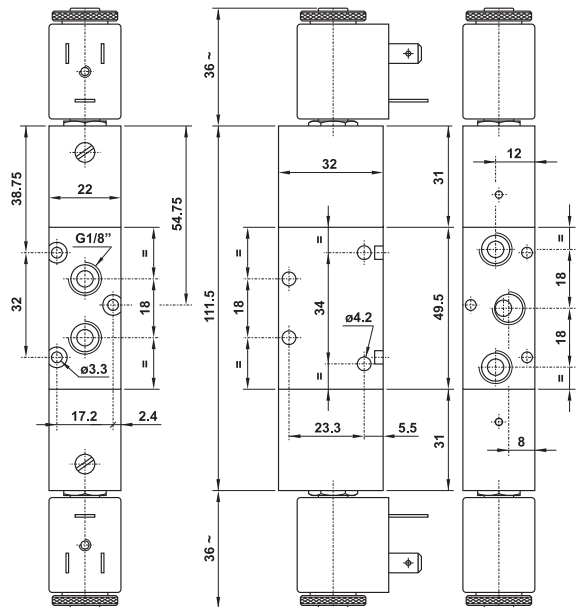

521 EED

5/2 1/8" doppio comando elettrico - con differenziale

5/2 1/8" double solenoid pilot - with differential

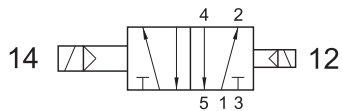

SOLO VERSIONE IN ALLUMINIO
ONLY ALUMINIUM VERSION

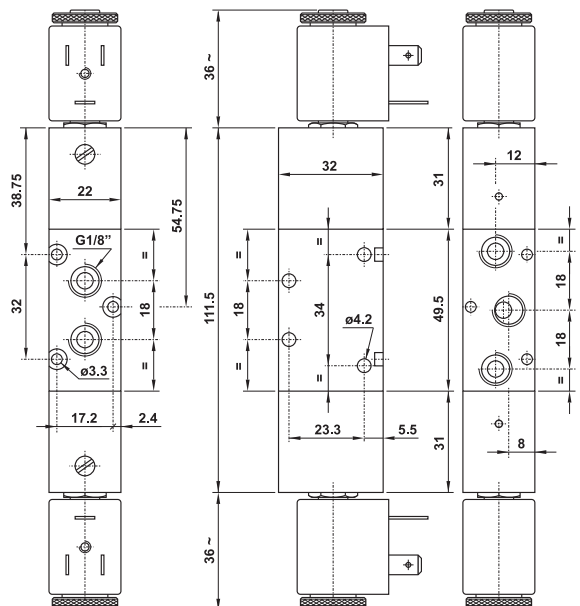

valvole ad azionamento elettropneumatico

solenoid actuated valves



521 EFP

5/2 1/8" comando elettrico - ritorno a molla pneumatica

5/2 1/8" solenoid pilot - pneumatic spring return

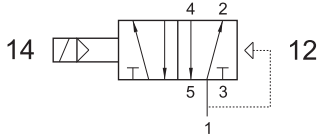

SOLO VERSIONE IN ALLUMINIO
ONLY ALUMINIUM VERSION

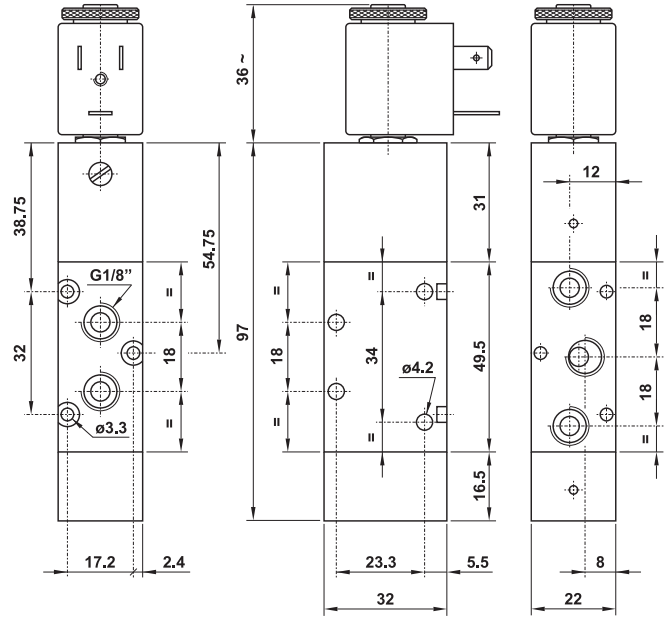

321 EE AS

3/2 1/8" doppio comando elettrico alimentazione separata

3/2 1/8" double solenoid pilot with separate air supply

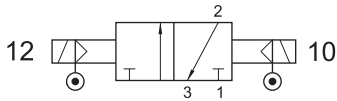

SOLO VERSIONE IN ALLUMINIO
ONLY ALUMINIUM VERSION

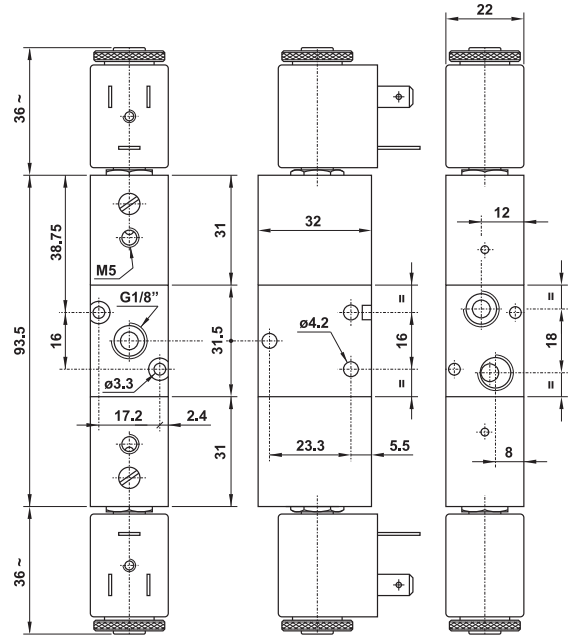

521 EE AS

5/2 1/8" doppio comando elettrico alimentazione separata

5/2 1/8" double solenoid pilot with separate air supply

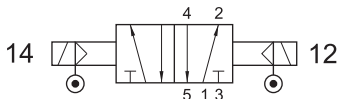

SOLO VERSIONE IN ALLUMINIO
ONLY ALUMINIUM VERSION

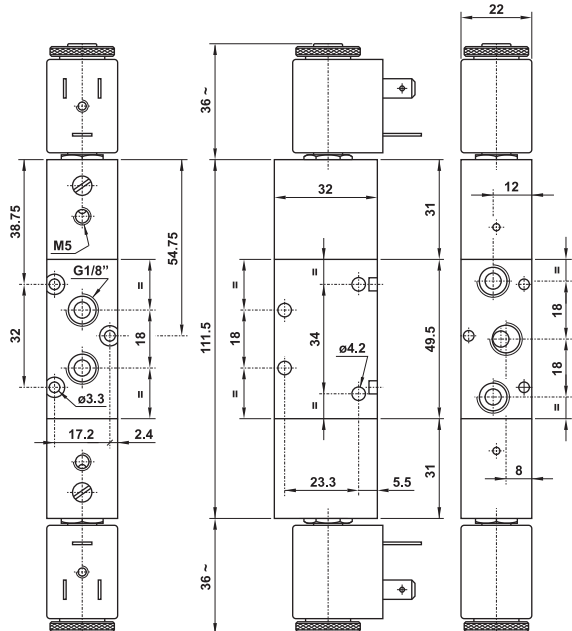

valvole ad azionamento elettropneumatico

solenoid actuated valves



5213C EE centri chiusi
closed centres

5213A EE centri aperti
open centres

5213P EE centri in pressione
pressurized centres

5/3 1/8" doppio comando elettrico

5/3 1/8" double solenoid pilot

SOLO VERSIONE IN ALLUMINIO

ONLY ALUMINIUM VERSION

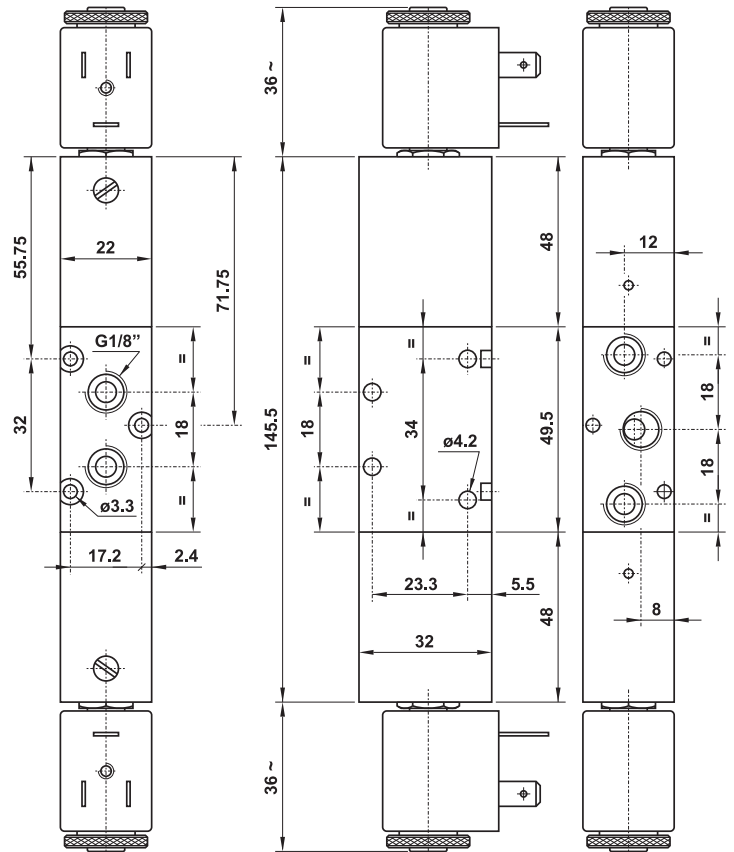
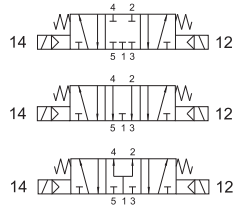

5213C EE AS centri chiusi
closed centres

5213A EE AS centri aperti
open centres

5213P EE AS centri in pressione
pressurized centres

5/3 1/8" doppio comando elettrico alimentazione separata

5/3 1/8" double solenoid pilot with separate air supply

SOLO VERSIONE IN ALLUMINIO

ONLY ALUMINIUM VERSION

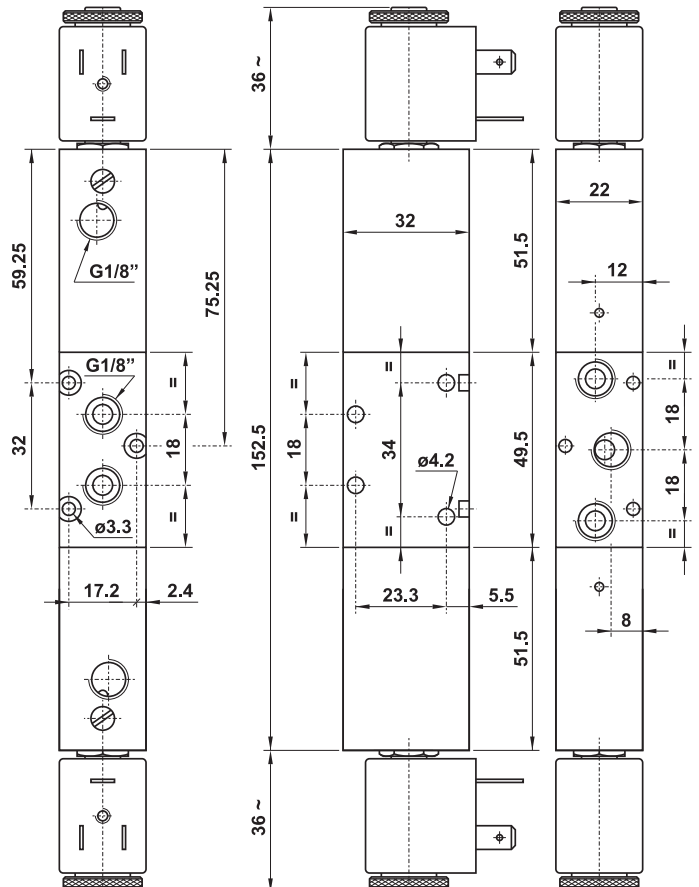
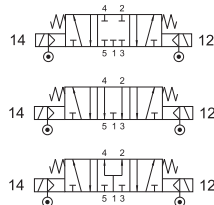



321 MRE

3/2 1/8" NC comando elettrico - ritorno a molla RINFORZATA

3/2 1/8" NC solenoid pilot - REINFORCED spring return

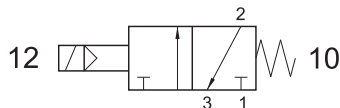

Non può essere utilizzata come valvola normalmente aperta.
It cannot be used as normally open valve.

Pressione di esercizio: 2.5 ... 10 bar

Working pressure: 2.5 ... 10 bar

La molla rinforzata permette un ritorno efficace della spola anche in assenza di aria.
The reinforced spring allows a prompt return of the spool also in lack of air.

Attenzione: il fondello per molla rinforzata è più lungo rispetto al fondello di una valvola con ritorno a molla normale.

Attention: the bottom end cap for reinforced spring return is longer than the end cap for normal spring return.

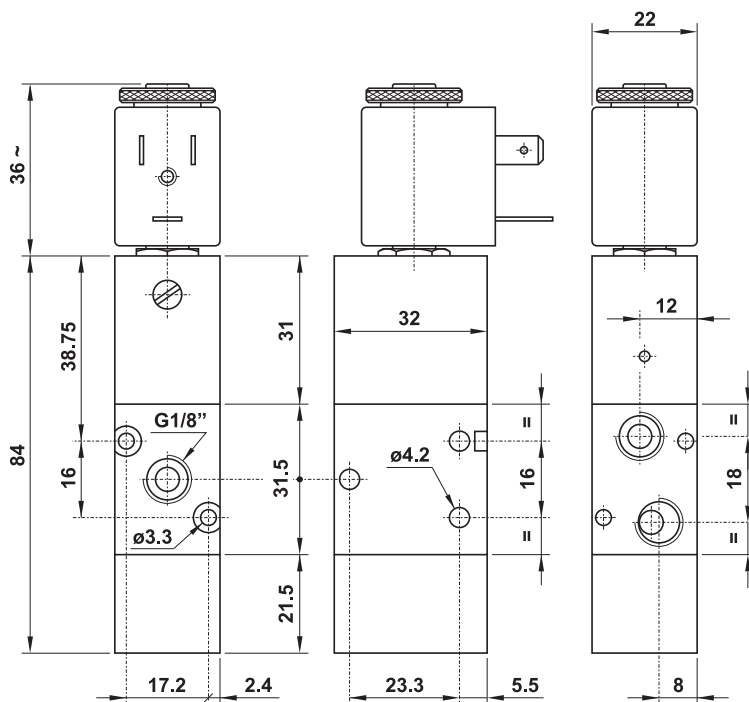

521 MRE

5/2 1/8" comando elettrico - ritorno a molla RINFORZATA

5/2 1/8" solenoid pilot - REINFORCED spring return

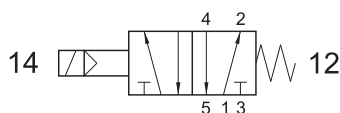

Pressione di esercizio: 2.5 ... 10 bar

Working pressure: 2.5 ... 10 bar

La molla rinforzata permette un ritorno efficace della spola anche in assenza di aria.
The reinforced spring allows a prompt return of the spool also in lack of air.

Attenzione: il fondello per molla rinforzata è più lungo rispetto al fondello di una valvola con ritorno a molla normale.

Attention: the bottom end cap for reinforced spring return is longer than the end cap for normal spring return.

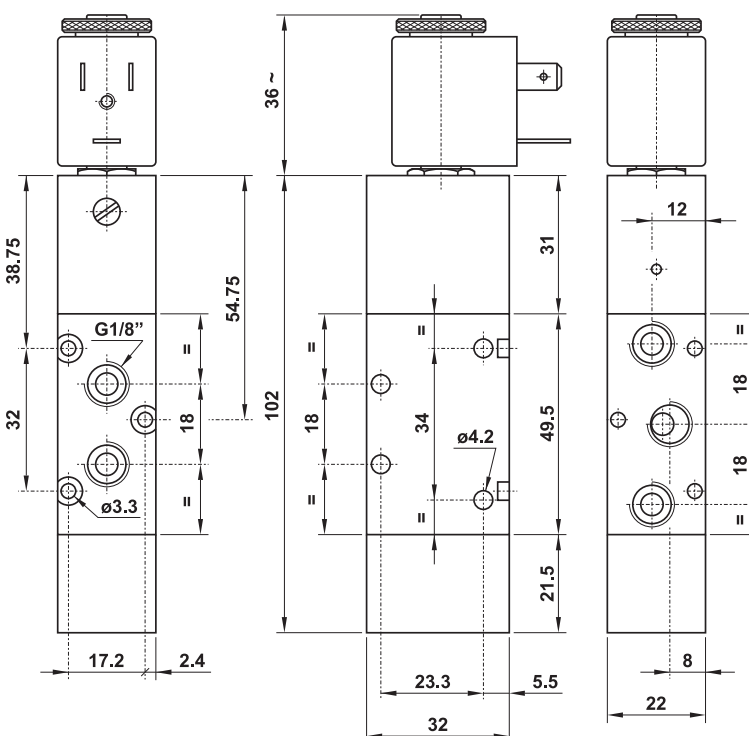

valvole ad azionamento elettropneumatico

solenoid actuated valves



321 ME90 S

3/2 1/8" NC comando elettrico 90° sul lato stretto - ritorno a molla
3/2 1/8" NC 90° solenoid pilot on the narrow side for compact assembly - spring return

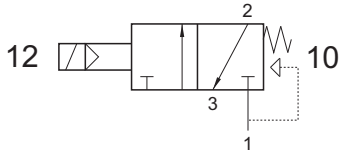

Non può essere utilizzata come valvola normalmente aperta.
It cannot be used as normally open valve.

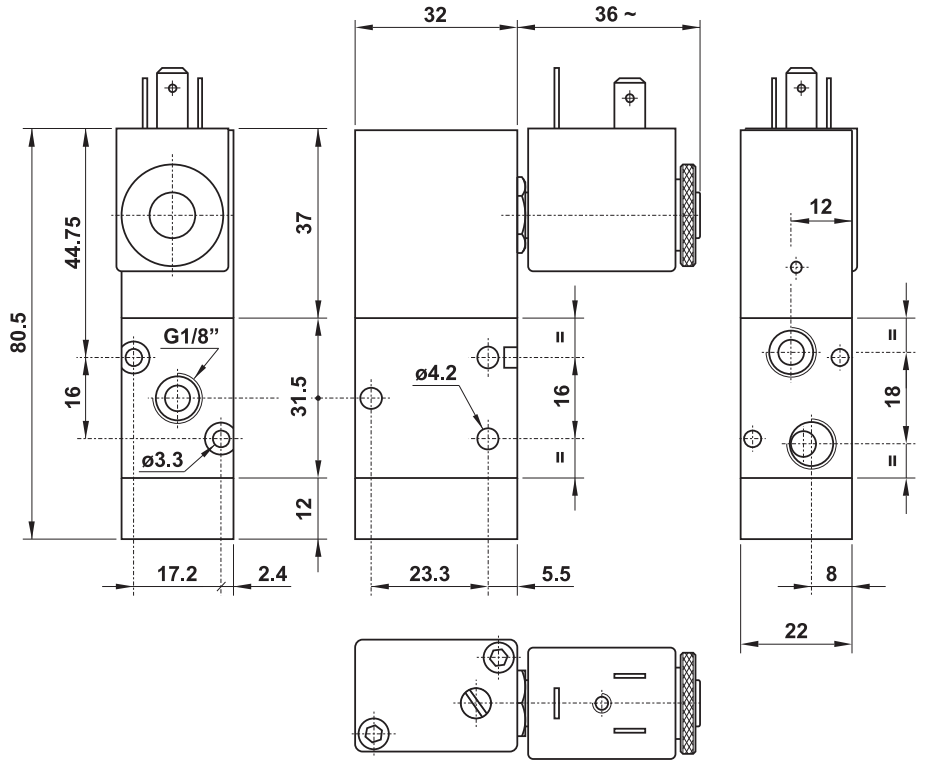

321 ME90 L

3/2 1/8" NC comando elettrico 90° sul lato largo - ritorno a molla
3/2 1/8" NC 90° solenoid pilot on the wide side - spring return

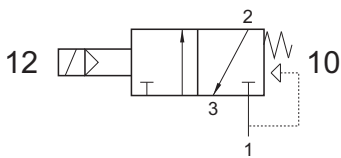

Non può essere utilizzata come valvola normalmente aperta.
It cannot be used as normally open valve.

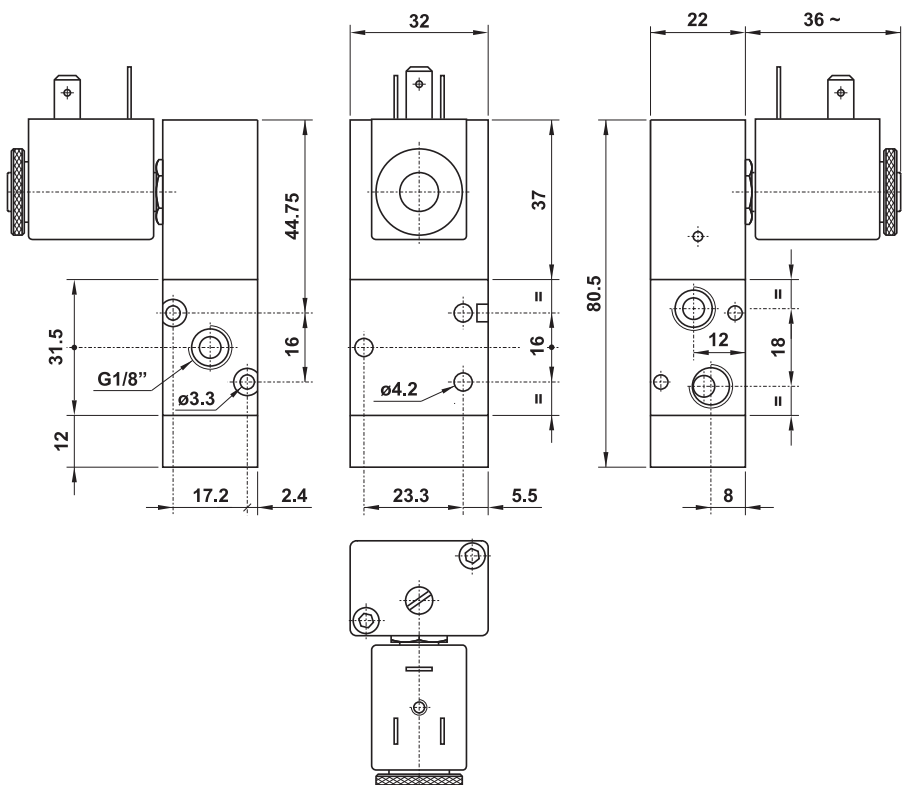

521 ME90 S

5/2 1/8" comando elettrico 90° sul lato stretto - ritorno a molla

5/2 1/8" 90° solenoid pilot on the narrow side for compact assembly - spring return

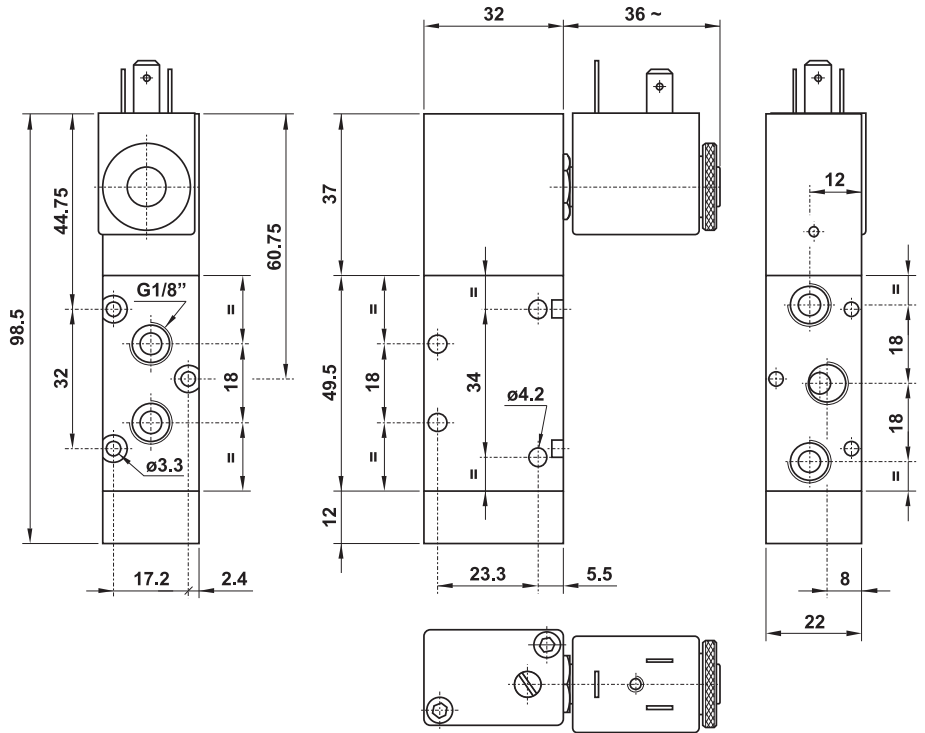
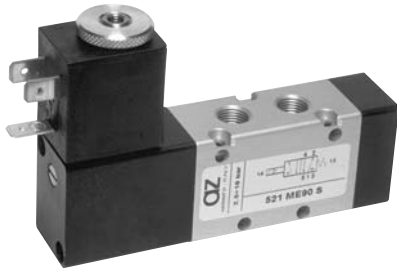
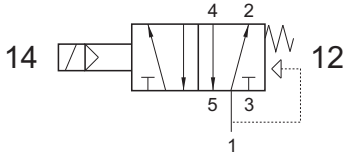

521 ME90 L

5/2 1/8" comando elettrico 90° sul lato largo - ritorno a molla

5/2 1/8" 90° solenoid pilot on the wide side - spring return

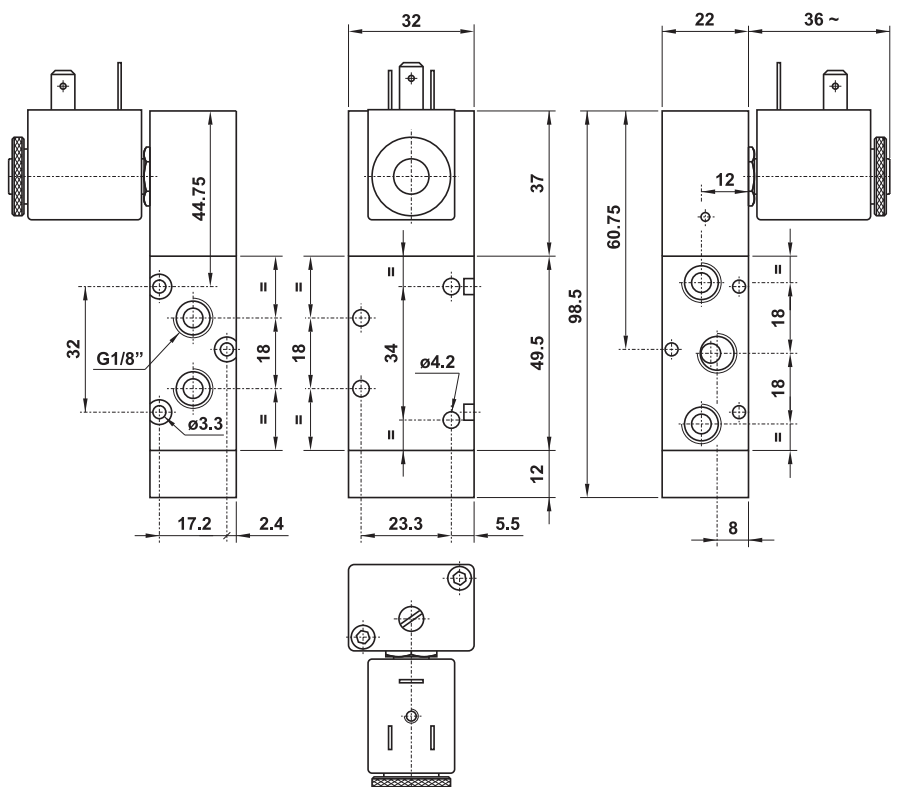
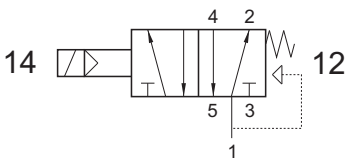

321 EE90 S

3/2 1/8" doppio comando elettrico 90° sul lato stretto

3/2 1/8" 90° double solenoid pilot on the narrow side for compact assembly

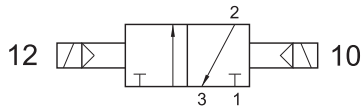

SOLO VERSIONE IN ALLUMINIO
ONLY ALUMINIUM VERSION

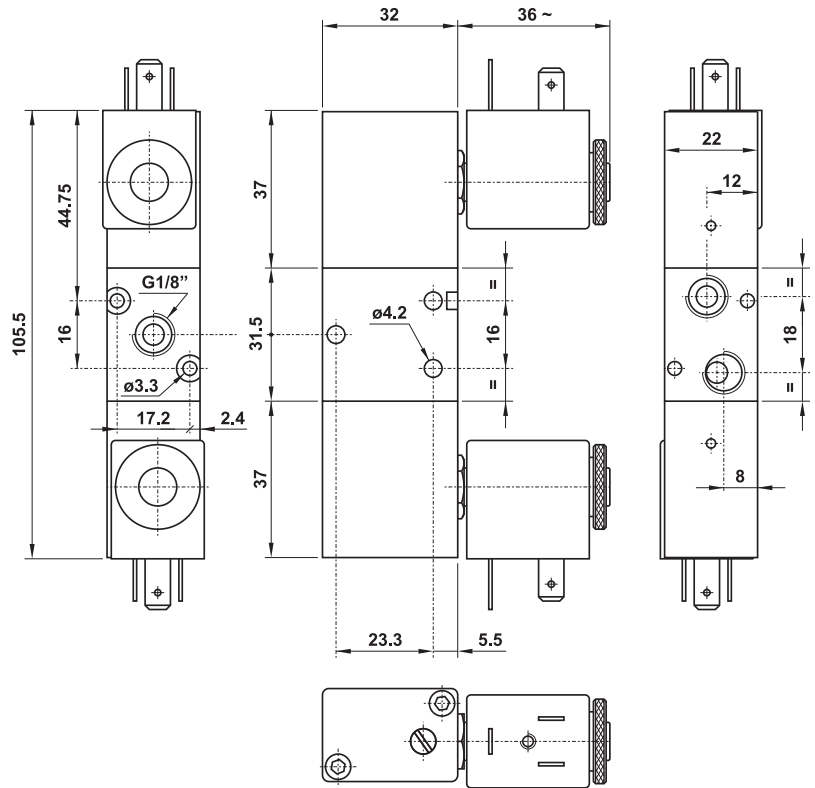
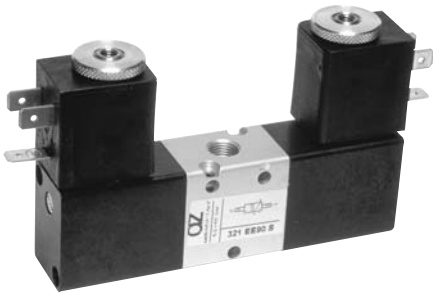

321 EE90 L

3/2 1/8" doppio comando elettrico 90° sul lato largo

3/2 1/8" 90° double solenoid pilot on the wide side

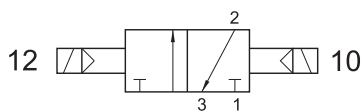

SOLO VERSIONE IN ALLUMINIO
ONLY ALUMINIUM VERSION

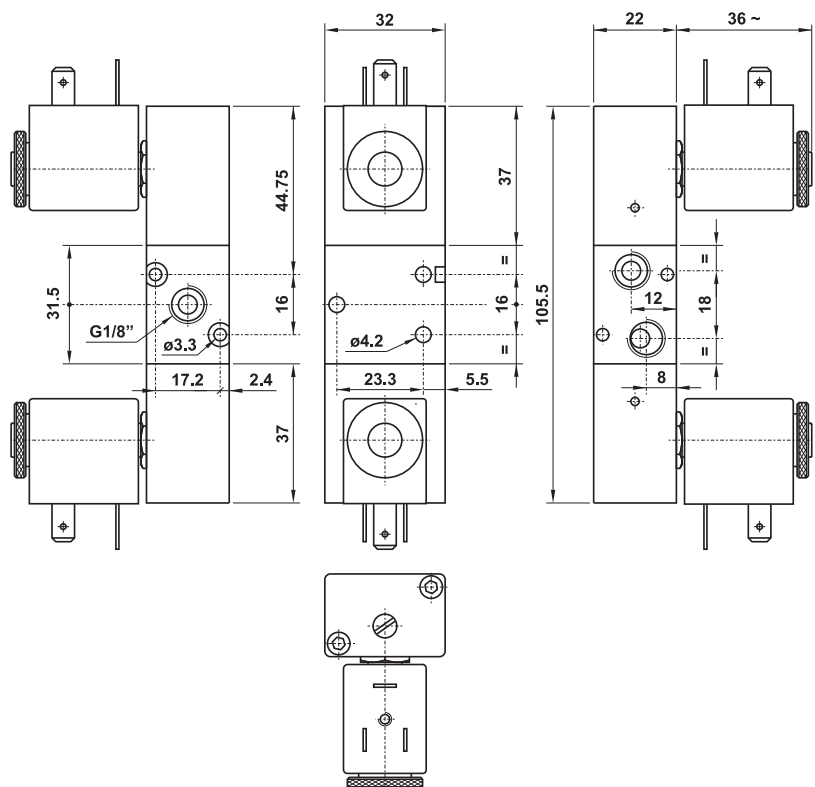

521 EE90 S

5/2 1/8" doppio comando elettrico 90° sul lato stretto

5/2 1/8" 90° double solenoid pilot on the narrow side for compact assembly

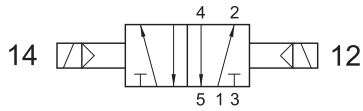

SOLO VERSIONE IN ALLUMINIO
ONLY ALUMINIUM VERSION

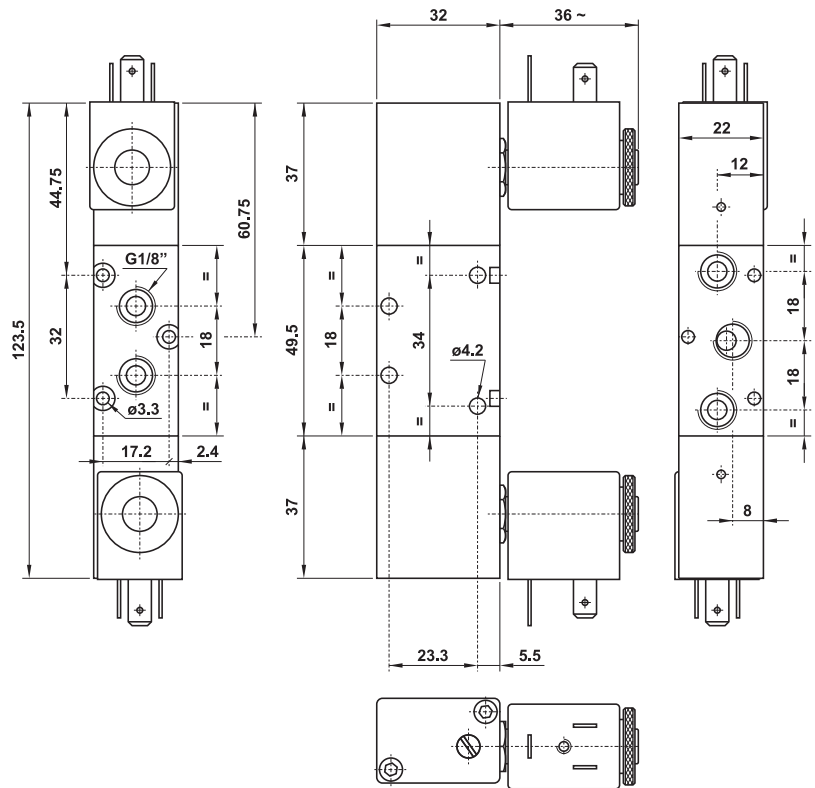
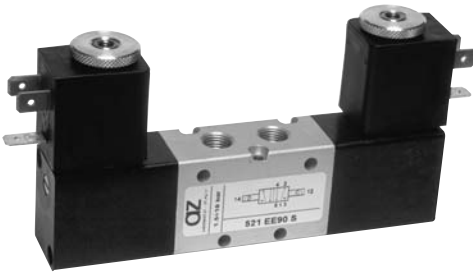

521 EE90 L

5/2 1/8" doppio comando elettrico 90° sul lato largo

5/2 1/8" 90° double solenoid pilot on the wide side

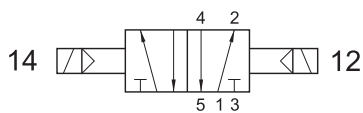

SOLO VERSIONE IN ALLUMINIO
ONLY ALUMINIUM VERSION

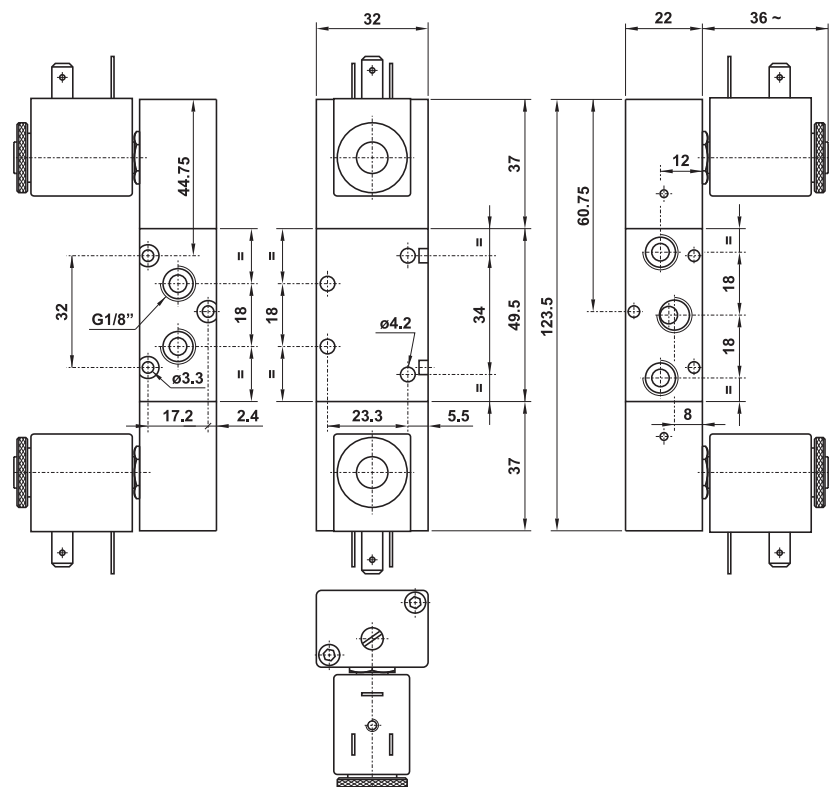

valvole ad azionamento elettropneumatico

solenoid actuated valves



322 ME

3/2 1/4" NC comando elettrico - ritorno a molla

3/2 1/4" NC solenoid pilot - spring return

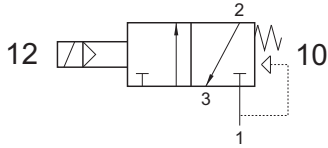

Non può essere utilizzata come valvola normalmente aperta.
It cannot be used as normally open valve.

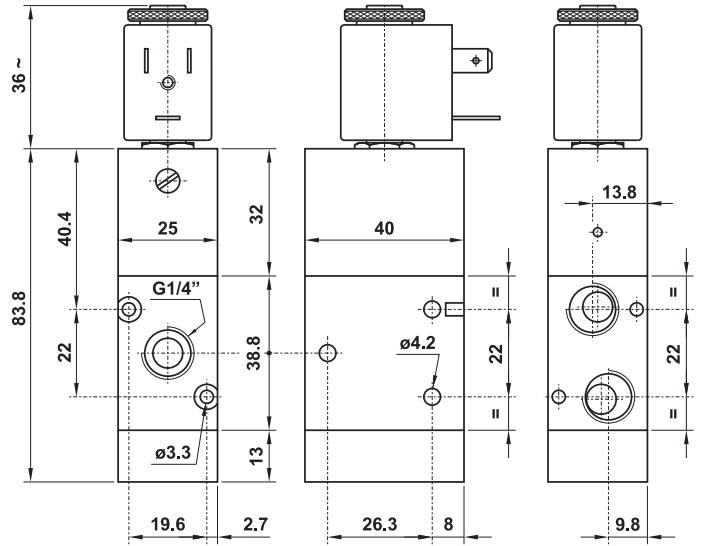

322 MEA

3/2 1/4" NA comando elettrico - ritorno a molla

3/2 1/4" NO solenoid pilot - spring return

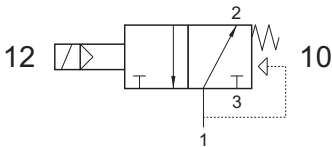

Non può essere utilizzata come valvola normalmente chiusa.
It cannot be used as normally closed valve.

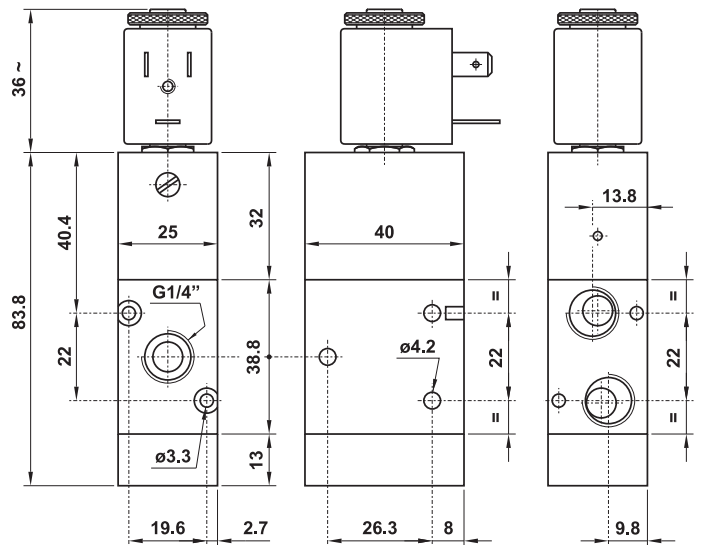

322 CE

3/2 1/4" comando elettrico - ritorno a comando pneumatico

3/2 1/4" solenoid pilot - separate pneumatically piloted return

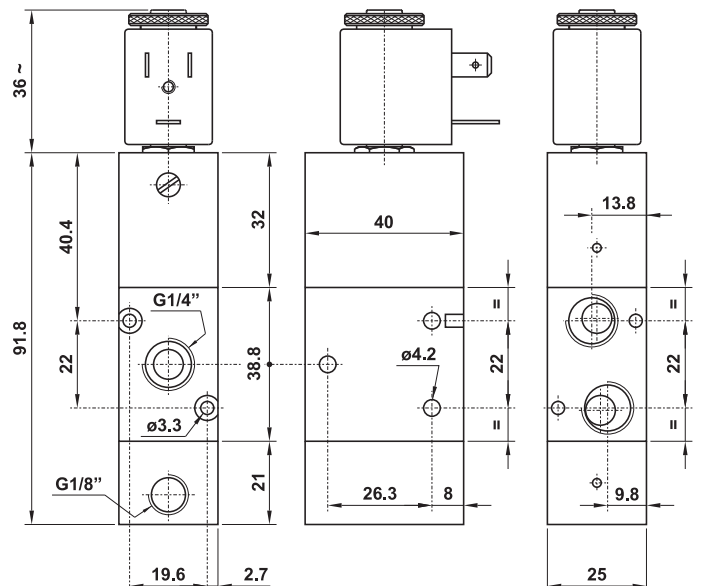
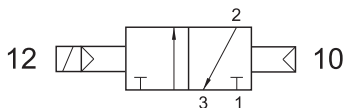

valvole ad azionamento elettropneumatico

solenoid actuated valves



522 ME

5/2 1/4" comando elettrico - ritorno a molla

5/2 1/4" solenoid pilot - spring return

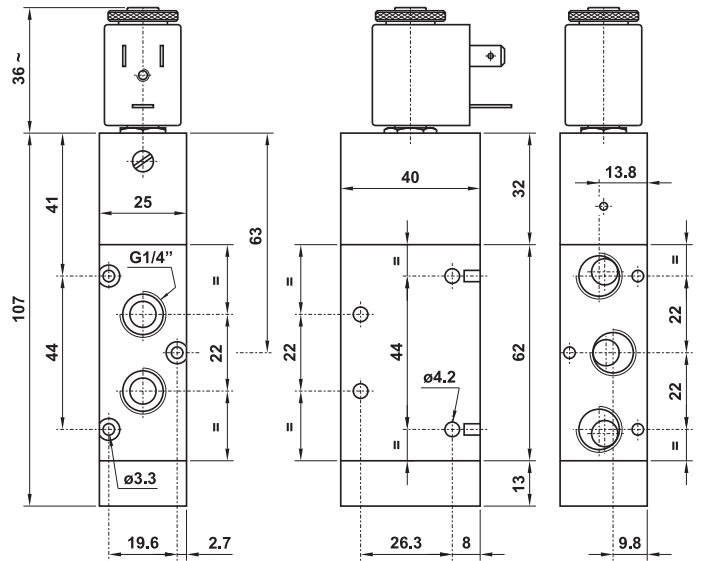
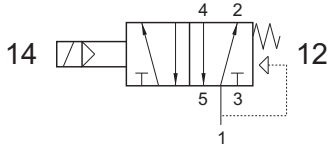

522 CE

5/2 1/4" comando elettrico - ritorno a comando pneumatico

5/2 1/4" solenoid pilot - separate pneumatically piloted return

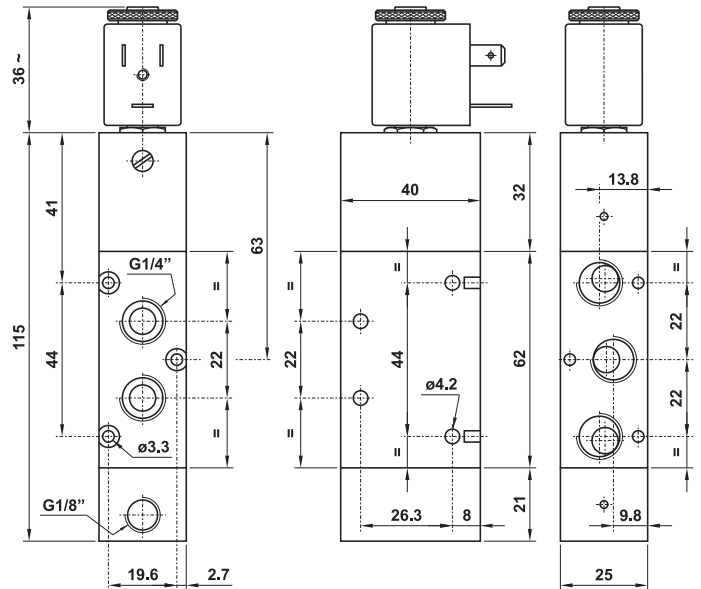
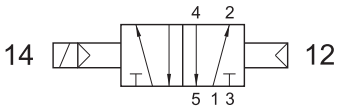

322 ME AS

3/2 1/4" comando elettrico alimentazione separata - ritorno a molla

3/2 1/4" solenoid pilot with separate air supply - spring return

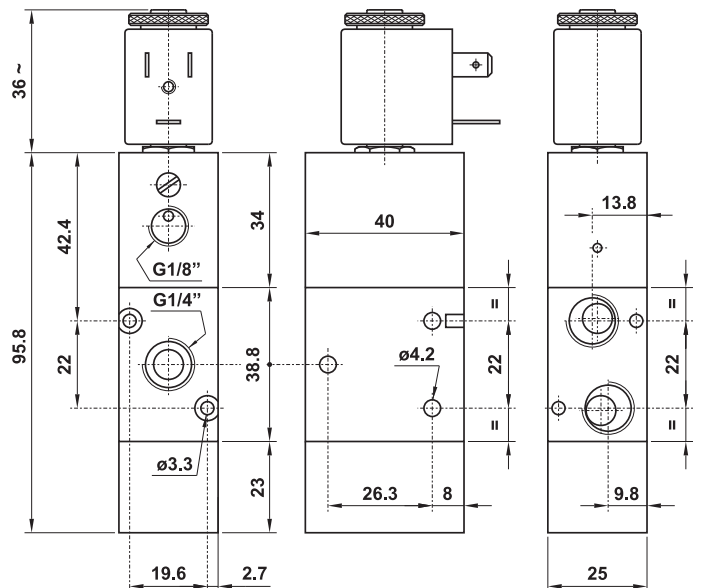
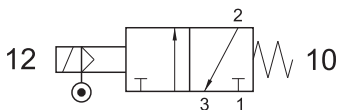

valvole ad azionamento elettropneumatico

solenoid actuated valves



522 ME AS

5/2 1/4" comando elettrico alimentazione separata - ritorno a molla
 5/2 1/4" solenoid pilot with separate air supply - spring return

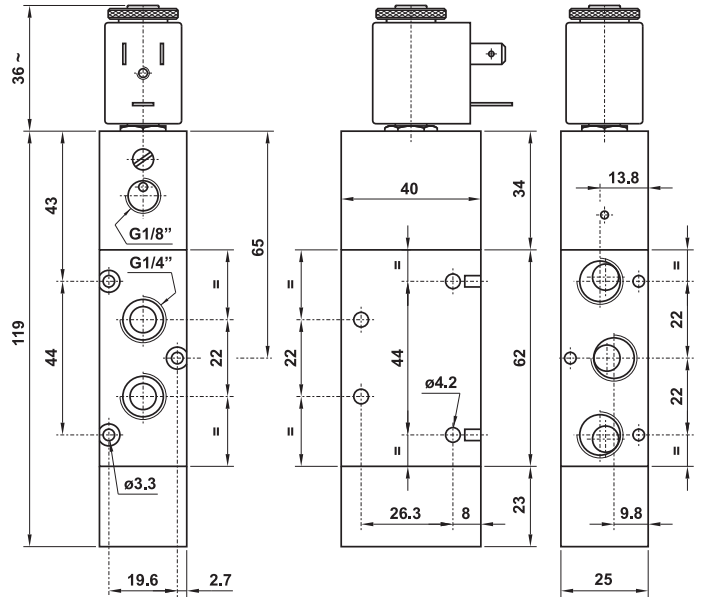
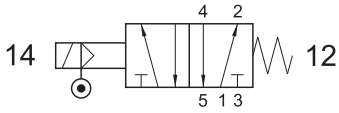

322 EE

3/2 1/4" doppio comando elettrico
 3/2 1/4" double solenoid pilot

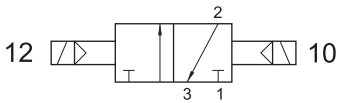

SOLO VERSIONE IN ALLUMINIO
 ONLY ALUMINIUM VERSION

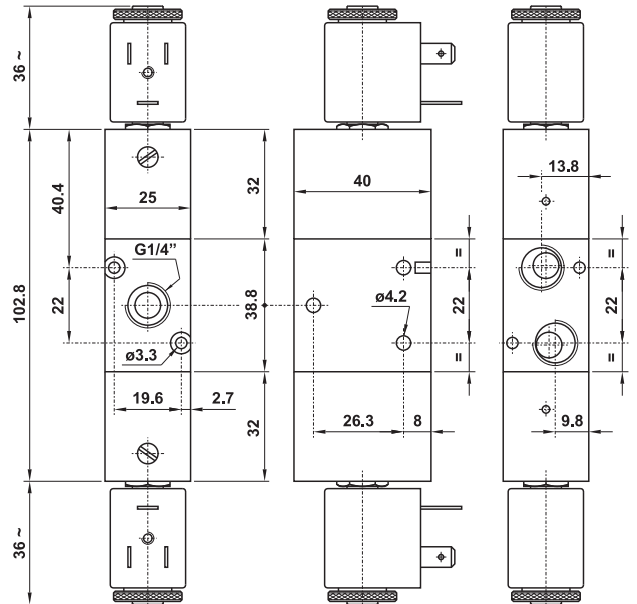

322 EED

3/2 1/4" doppio comando elettrico - con differenziale
 3/2 1/4" double solenoid pilot - with differential

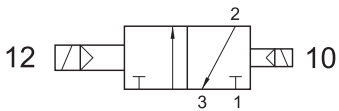

SOLO VERSIONE IN ALLUMINIO
 ONLY ALUMINIUM VERSION

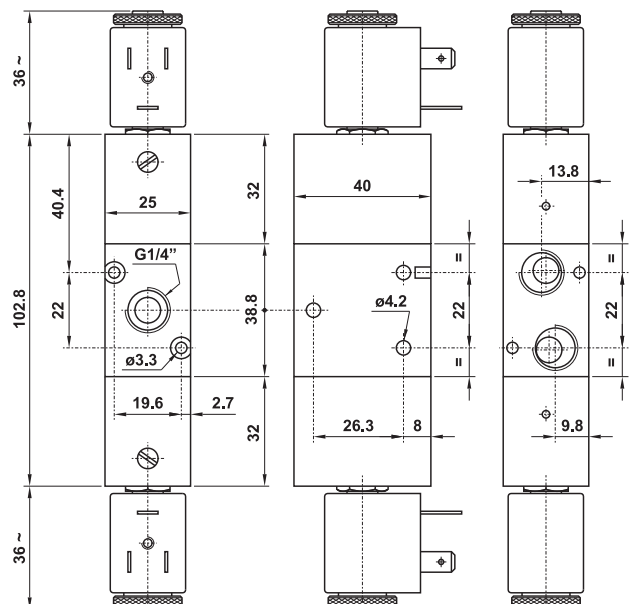

valvole ad azionamento elettropneumatico

solenoid actuated valves



322 EFP

3/2 1/4" NC comando elettrico - ritorno a molla pneumatica

3/2 1/4" NC solenoid pilot - pneumatic spring return

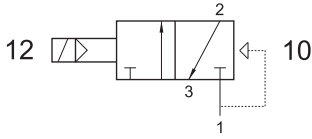

Non può essere utilizzata come valvola normalmente aperta.
It cannot be used as normally open valve.

SOLO VERSIONE IN ALLUMINIO
ONLY ALUMINIUM VERSION

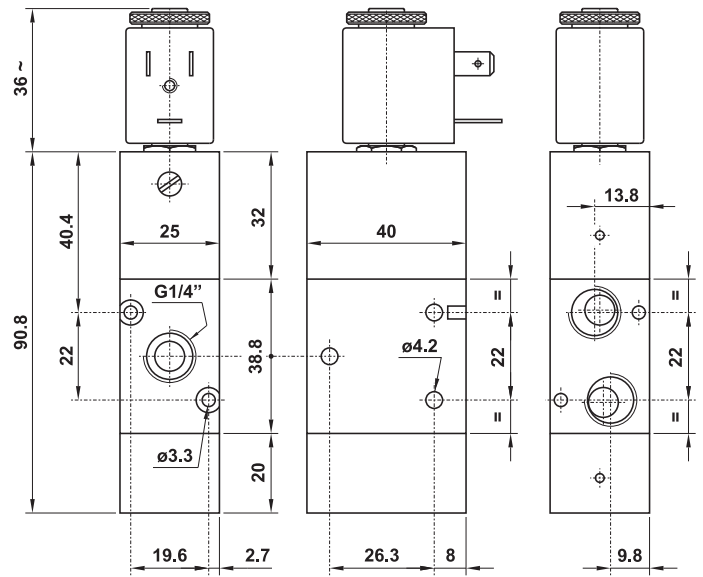

522 EE

5/2 1/4" doppio comando elettrico

5/2 1/4" double solenoid pilot

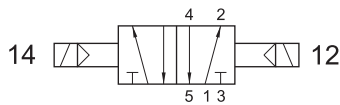

SOLO VERSIONE IN ALLUMINIO
ONLY ALUMINIUM VERSION

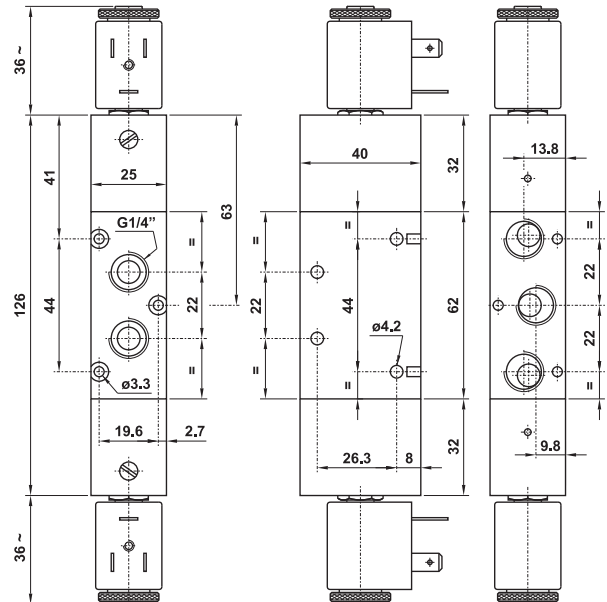

522 EED

5/2 1/4" doppio comando elettrico - con differenziale

5/2 1/4" double solenoid pilot - with differential

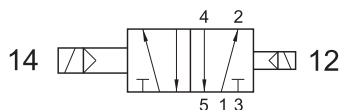

SOLO VERSIONE IN ALLUMINIO
ONLY ALUMINIUM VERSION

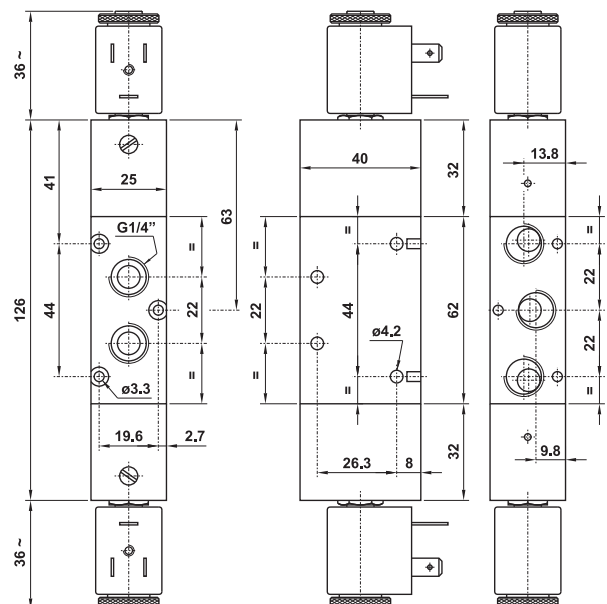

valvole ad azionamento elettropneumatico

solenoid actuated valves



522 EFP

5/2 1/4" comando elettrico - ritorno a molla pneumatica

5/2 1/4" solenoid pilot - pneumatic spring return

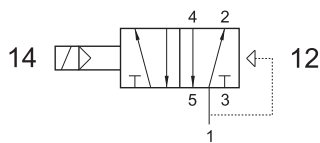

SOLO VERSIONE IN ALLUMINIO
ONLY ALUMINIUM VERSION

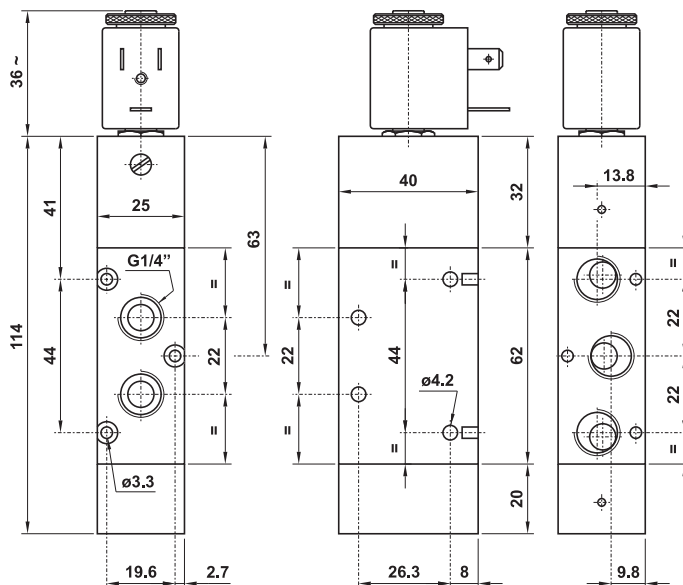

322 EE AS

3/2 1/4" doppio comando elettrico alimentazione separata

3/2 1/4" double solenoid pilot with separate air supply

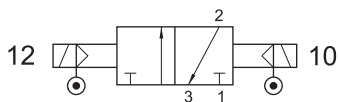

SOLO VERSIONE IN ALLUMINIO
ONLY ALUMINIUM VERSION

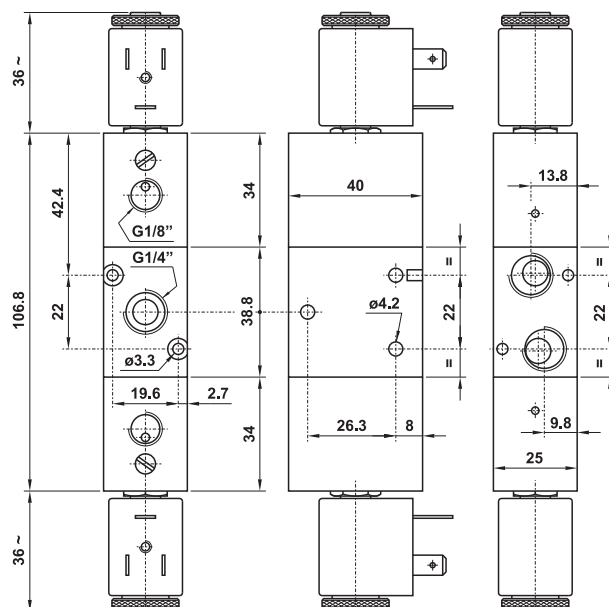

522 EE AS

5/2 1/4" doppio comando elettrico alimentazione separata

5/2 1/4" double solenoid pilot with separate air supply

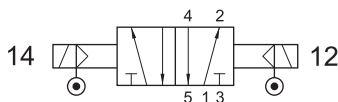

SOLO VERSIONE IN ALLUMINIO
ONLY ALUMINIUM VERSION

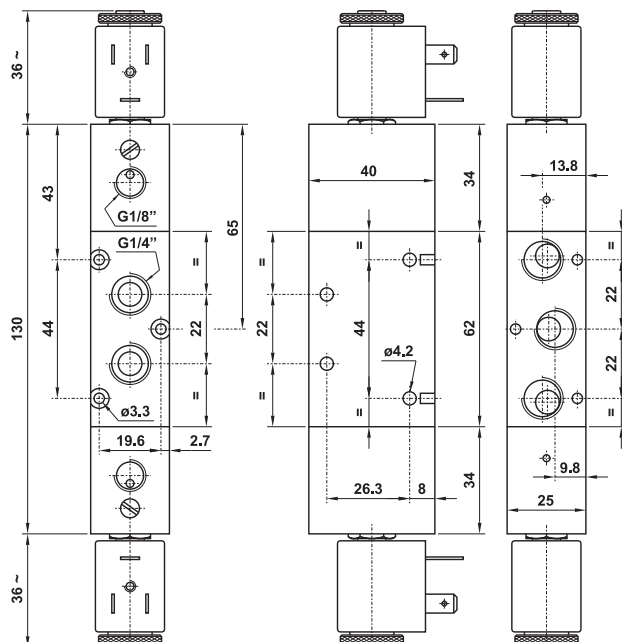

valvole ad azionamento elettropneumatico

solenoid actuated valves



322 MRE

3/2 1/4" NC comando elettrico - ritorno a molla RINFORZATA

3/2 1/4" NC solenoid pilot - REINFORCED spring return

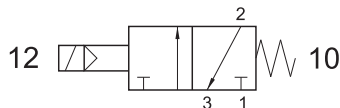

Non può essere utilizzata come valvola normalmente aperta.
It cannot be used as normally open valve.

Pressione di esercizio: 2.5 ... 10 bar

Working pressure: 2.5 ... 10 bar

La molla rinforzata permette un ritorno efficace della spola anche in assenza di aria.

The reinforced spring allows a prompt return of the spool also in lack of air.

Attenzione: il fondello per molla rinforzata è più lungo rispetto al fondello di una valvola con ritorno a molla normale.

Attention: the bottom end cap for reinforced spring return is longer than the end cap for normal spring return.

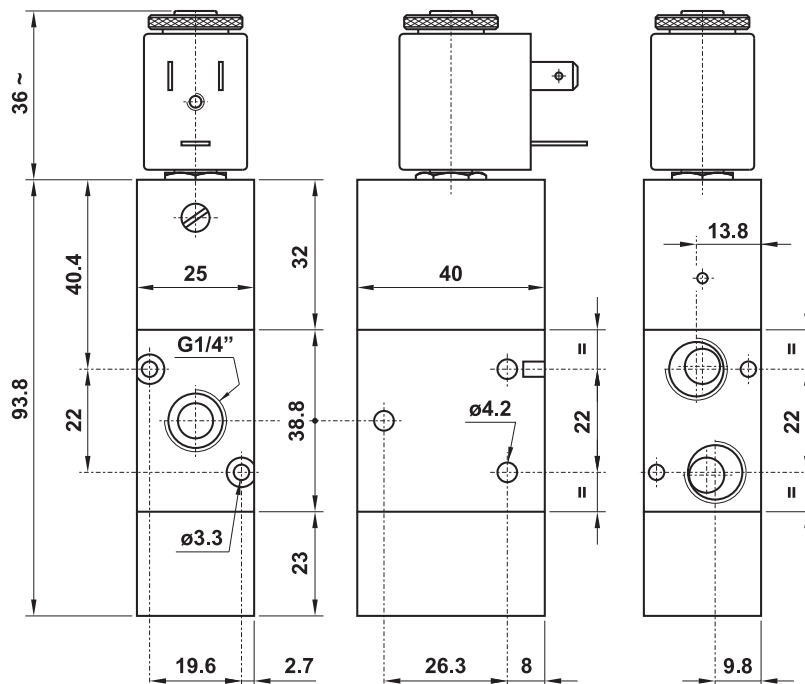

522 MRE

5/2 1/4" comando elettrico - ritorno a molla RINFORZATA

5/2 1/4" solenoid pilot - REINFORCED spring return

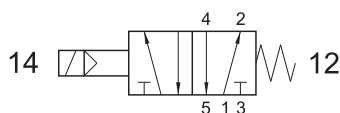

Pressione di esercizio: 2.5 ... 10 bar

Working pressure: 2.5 ... 10 bar

La molla rinforzata permette un ritorno efficace della spola anche in assenza di aria.

The reinforced spring allows a prompt return of the spool also in lack of air.

Attenzione: il fondello per molla rinforzata è più lungo rispetto al fondello di una valvola con ritorno a molla normale.

Attention: the bottom end cap for reinforced spring return is longer than the end cap for normal spring return.

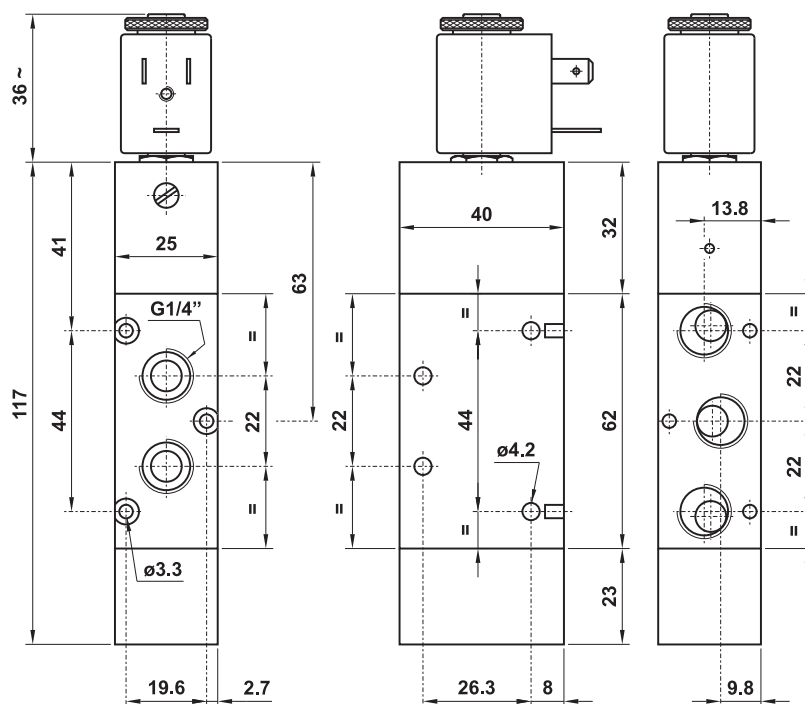

ricambi per valvole a spola

spare parts for spool valves

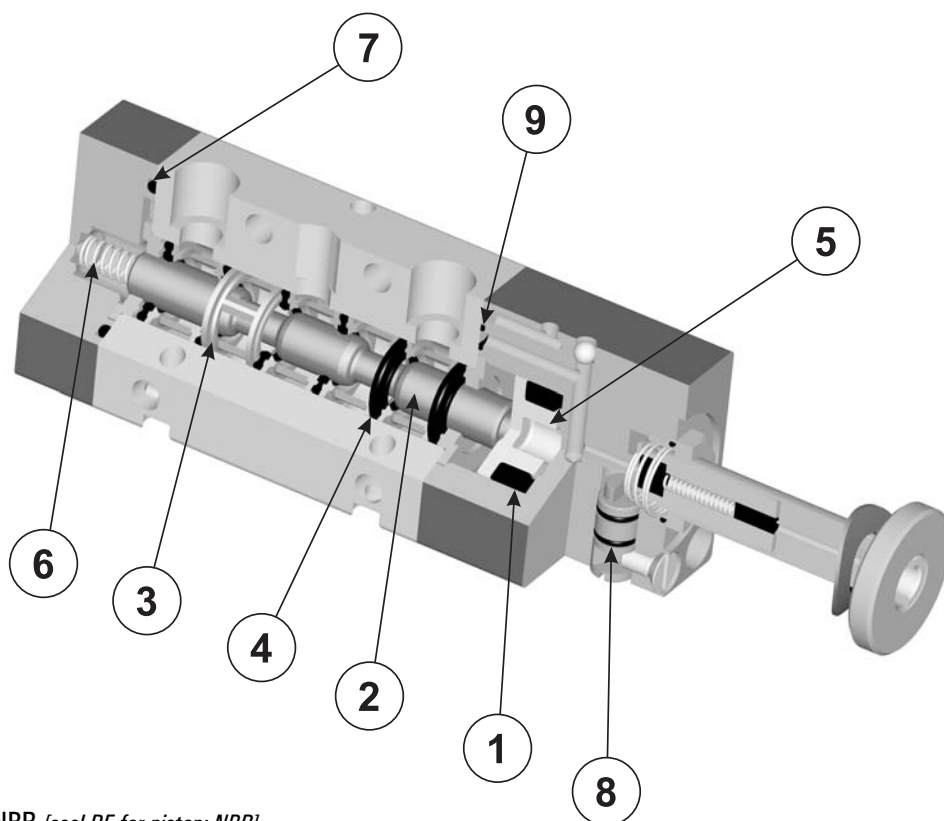

1. Guarnizione DE per pistone: NBR [seal DE for piston: NBR]
2. Spola: alluminio 11S nichelato [spool: aluminium 11S, nickeled]
3. Distanziale cassetto: ottone [brass]
4. Guarnizione cassetto: NBR [seal for spool: NBR]
5. Pistone per comando spola: delrin [piston to actuate the spool: delrin]
6. Molla: acciaio [spring: steel]
7. Guarnizione O-Ring: NBR
8. Guarnizione O-Ring 4x1: NBR
9. Guarnizione O-Ring sagomato: NBR [shaped O-Ring: NBR]

codice kit code of kit	utilizzabile per suitable for		
00.036.2	321 MC	321 MCA	321 ME
	321 MEA	321 ME90 S	321 ME90 L
00.039.2	521 MC	521 ME	521 ME90 S
	521 ME90 L		
00.037.2	321 CC	321 EE	321 CE
	321 EE AS	321 EE90 S	321 EE90 L
00.040.2	521 CC	521 EE	521 CE
	521 EE AS	521 EE90 S	521 EE90 L
01.014.2	322 MC	322 MC SUP	322 MCA
	322 ME	322 MEA	
01.020.2	522 MC	522 MC SUP	522 ME
01.015.2	322 CC	322 CC SUP	322 CE
	322 EE	322 EE AS	
01.021.2	522 CC	522 CC SUP	522 CE
	522 EE	522 EE AS	

codice kit code of kit	utilizzabile per suitable for		
00.038.2	321 EED	321 EFP	321 CCD
	321 CFP		
00.041.2	521 EED	521 EFP	521 CCD
	521 CFP		
01.019.2	322 EED	322 EFP	322 CCD
	322 CFP		
01.022.2	522 EED	522 EFP	522 CCD
	522 CFP		
00.050.2	321 ME AS		
01.035.2	322 ME AS		
00.051.2	521 ME AS		
01.036.2	522 ME AS		
00.108.2	5213C CC	5213A CC	5213P CC
	5213C EE	5213A EE	5213P EE
	5213C EE AS	5213A EE AS	5213P EE AS
01.061.2	5223C CC	5223A CC	5223P CC
	5223C EE	5223A EE	5223P EE
	5223C EE AS	5223A EE AS	5223P EE AS

bobine e connettori 22 mm

22 mm coils and connectors



22 mm



temperatura max di esercizio	+50°C	<i>max working temperature</i>
inserimento	ED 100%	<i>duty cycle</i>
protezione con connettore correttamente montato	IP 65	<i>protection with connector correctly mounted</i>
tolleranza di tensione	±10%	<i>tension tolerance</i>

- a richiesta basso assorbimento 24V DC 1.5W: **00.196.0**
low consumption (24V DC 1.5W) on request: 00.196.0

codice <i>code</i>	tensione <i>tension</i>	consumo - power	
		a regime <i>rated</i>	di spunto <i>inrush</i>
00.167.0	12V DC	3W	
00.028.0	24V DC	3W	
00.029.0	24V 50/60Hz	5VA	7.5VA
00.030.0	110V 50/60Hz	5VA	7.5VA
00.031.0	220V 50/60Hz	5VA	7.5VA

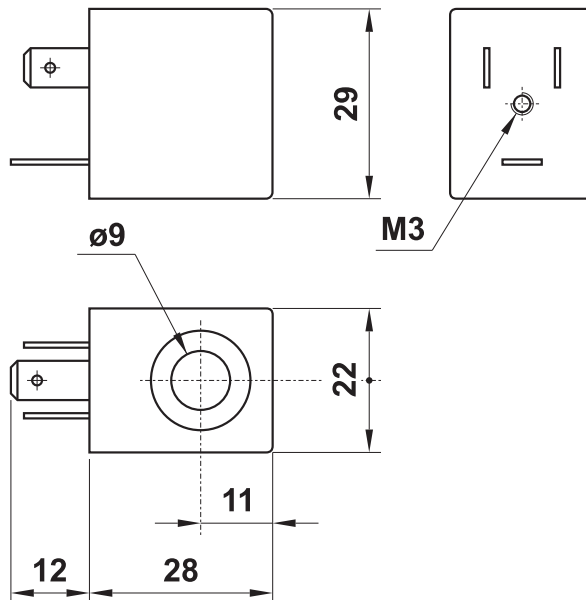

codice <i>code</i>	colore <i>colour</i>	cavo <i>cable</i>	tipo <i>type</i>
00.197.0	nero <i>black</i>	PG09	normale <i>standard</i>
00.344.0	trasparente <i>transparent</i>	PG09	con LED 24V <i>with LED 24V</i>
00.345.0	trasparente <i>transparent</i>	PG09	con LED 24V e VDR <i>with LED 24V and VDR</i>
00.346.0	trasparente <i>transparent</i>	PG09	con LED 115V <i>with LED 115V</i>
00.347.0	trasparente <i>transparent</i>	PG09	con LED 115V e VDR <i>with LED 115V and VDR</i>
00.394.0	trasparente <i>transparent</i>	PG09	con LED 230V <i>with LED 230V</i>
00.395.0	trasparente <i>transparent</i>	PG09	con LED 230V e VDR <i>with LED 230V and VDR</i>

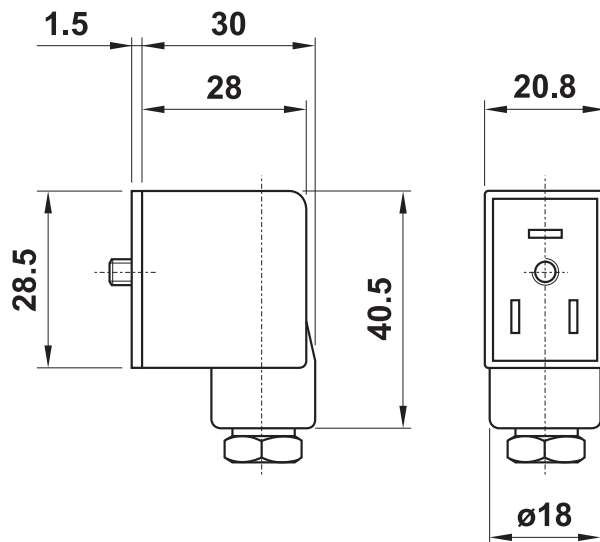

PEZZI DI RICAMBIO - spare parts

<p>canotto per elettropilota <i>armature for solenoid pilot</i></p> <p>NC : 00.088.0 NA (NO) : 00.306.0</p>	<p>ghiera in alluminio e rondella <i>aluminium nut and elastic ring</i></p> <p>00.125.2</p>
	<p>ghiera in plastica <i>nut in plastic material</i></p> <p>00.186.0</p>